

No. 226

Date 9/18/89

Another addition to the expanding line of Webb products.

NEW PRODUCT BULLETIN

PART NUMBER: **2024** and **2324** **HUBS**

DESCRIPTION: **8 Stud Hub**
(11.22/285mm Bolt Circle)

AVAILABLE
NOW

ESTIMATED WEIGHT: **2024 - 44 Lbs.**
2324 - 52 Lbs.

APPLICATION INFORMATION

**8 Hole 285mm B.C. Hub
with 20mm Diameter Studs**

FEATURES:

- Uses Outboard Mount Brake Drum
- Designed for Use with Asian 8 Hole Disc Wheel

2024

WEBB AXLE GROUP NO. 2

Outer Bearing Cup HM212011
Cone HM212049
Inner Bearing Cup HM218210
Cone HM218248

AXLE MODELS

Dana D-22, K-22
Dexter D200K, D225K
Eaton J, JE, JH, 23L, 23R, HJ, HJE, 25R, HR25
KB KBW, KBS
Rockwell RN, TKN, TN, TQ, RQ
Standard Forge A-22S

2324

WEBB AXLE GROUP NO. 4

Outer Bearing Cup HM518410
Cone HM518445
Inner Bearing Cup HM518410
Cone HM518445

AXLE MODELS

Dana P
Fruehauf PRO-PAR
Rockwell TP

"A" Hub Part No	Desc.	"B" Distance Between Caps	"C" Cup To MTG Face	"D" Cup to End of Drum	"E" Brake Drum		"F" Brake Drum		"H" Drum Over All Depth	"I" Pilot Dia.	"J" Bolt Circle	"K" Bolt Qty Dia.	"L" Hub Cap Hole Pattern	Hub Cap Kit	Stud Stand Out *
					Part No.	Order Code	Dia.	Width							
2024	8 Stud 11.22 B.C. OB Drum	3.34	.79	9.83	66879	GT	16.50	7.00	10.62	9.00	11.22	8 (0.75)	6HLS .31Ø 5.50Ø B.C.	73655	1.43
			.79	11.60	66818	ET	16.50	8.62	12.39	9.00	11.22 (285mm)				
2324	w/20mm Clipped Head Studs	4.50	1.79	8.83	66879	GT	16.50	7.00	10.62	9.00	11.22	8 (0.75)	6.25 x 8 TPI	Not Avail. from Webb	1.43
			1.79	10.60	66818	ET	16.50	8.62	12.39	9.00	11.22 (285mm)				

★ See Reverse Side for Sample Assembly Print Showing All Major Components and Stud Application Chart.

WEBB WHEEL PRODUCTS, INC.
2310 Industrial Drive, S.W.
Cullman, Alabama 35055
(205) 739-6660
FAX: 205-739-6246

DYNAMIC LOAD CAPACITY: 12,500 LBS. PER HUB

WEBB ORDER CODE: 202418TMR (R.H.)
202418TML (L.H.)

LIST OF COMPONENTS			
ITEM	PART #	DESCRIPTION	QTY.
1	2024F	HUB - 8 STUD - OUTBOARD	1
2	HM212011	OUTER BEARING CUP	1
3	HM218210	INNER BEARING CUP	1
4	101200	CLIPPED HEAD STUD - 20mm x 1.5 R.H.	8
	101201	CLIPPED HEAD STUD - 20mm x 1.5 L.H.	
5	66879F	BRAKE DRUM - 16.50 x 7.0	1

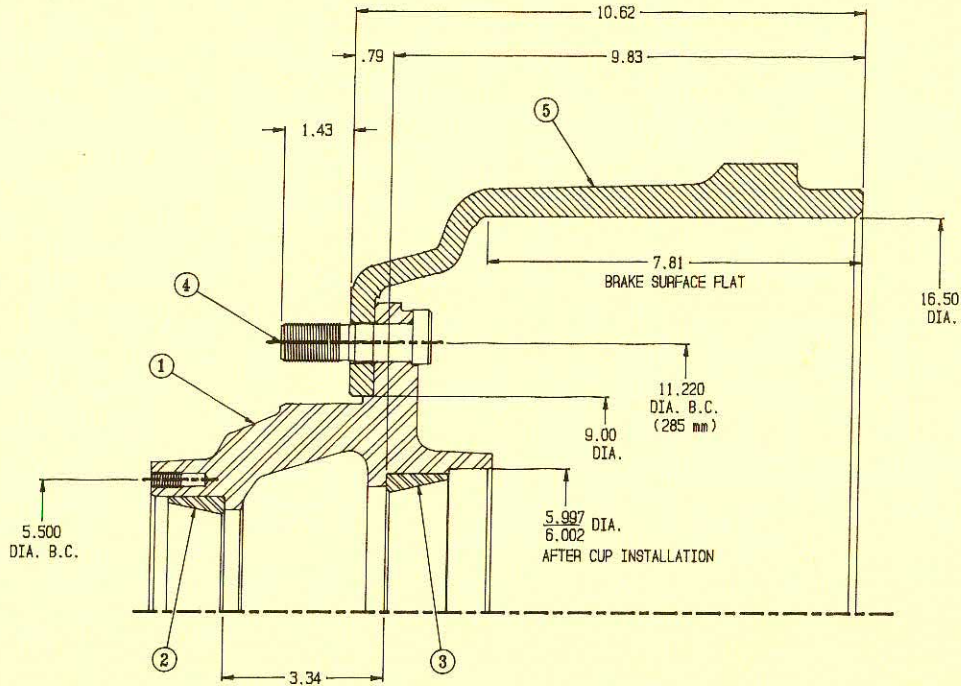

WEBB ORDER CODE: 232418TMR/L

DYNAMIC LOAD CAPACITY - 12,500 LBS. PER HUB

LIST OF COMPONENTS			
ITEM	PART NO.	DESCRIPTION	QTY.
1	2324F	HUB - 8 STUD - O.B.	1
2	HM518410	OUTER BEARING CUP	1
3	HM518410	INNER BEARING CUP	1
4	101200	CLIPPED HEAD STUD - 20mm x 1.5 R.H.	8
	101201	CLIPPED HEAD STUD - 20mm x 1.5 L.H.	
5	66879F	BRAKE DRUM - 16.50 X 7.0	1

